

# RO930

ROBINIA TELRAAM  
BOULIER EN ROBINIER  
ROBINIA ABACUS DISK PANEL  
ROBINIE RECHENSCHIEBER  
ROBINIA ABACO  
ROBINIA PALLOTTOLIERE

## Montagehandleiding Notice de montage Installation manual Montageanleitung Instrucciones para el montaje Istruzioni di installazione

Leeftijd  
Age group  
Age / Alter  
Edad / Età  
2 - 6

EUROPLAY nv  
Eegene 9  
B-9200 DENDERMONDE  
tel. 32.52.22 66 22  
fax.32.52.22 67 22  
www.europlay.eu

Dat.: 23/03/2023

Rev.:

Page: 1/1

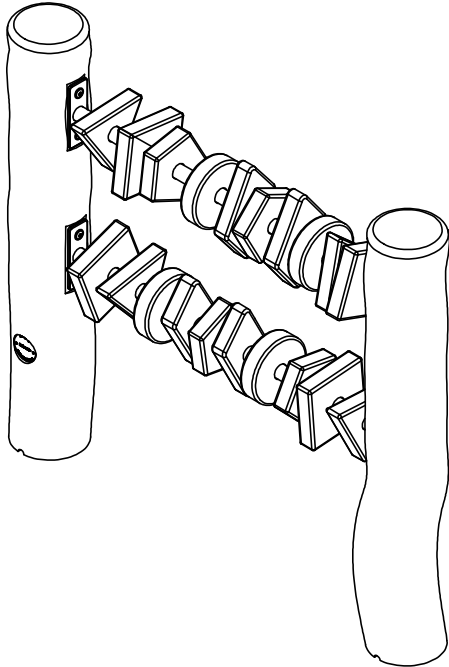

1135.75 x 800 x 160.96

±39kg

### Benodigdheden - Liste des pièces - Materials - Benötigtes - Accesorios - Requisiti

2x RO930-As-Telraam-01



950 x 120 x 120

4x M8x60

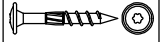

8x Ø4.5x50



1x RO930-H-A-01

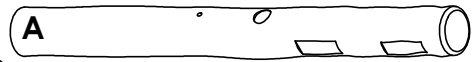

1400 x Ø130

15kg

1x RO930-H-B-01



1400 x Ø130

15kg

2x RO930-H-C-01

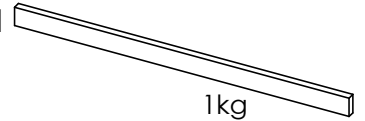

1000 x 57 x 22

1kg

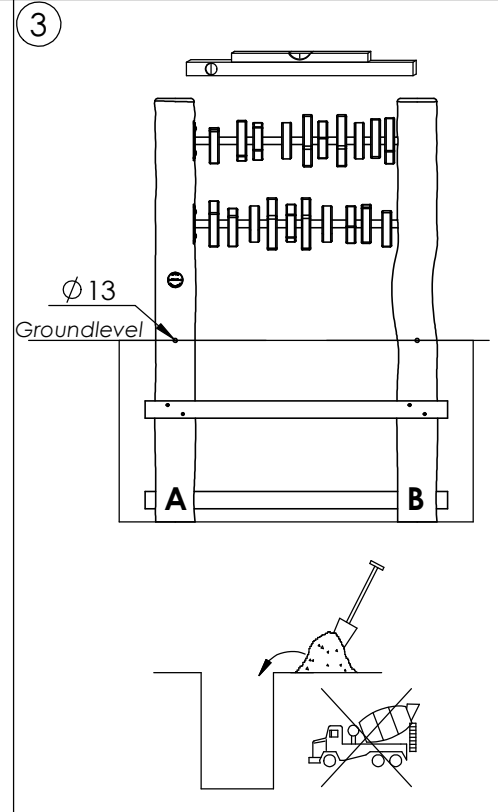
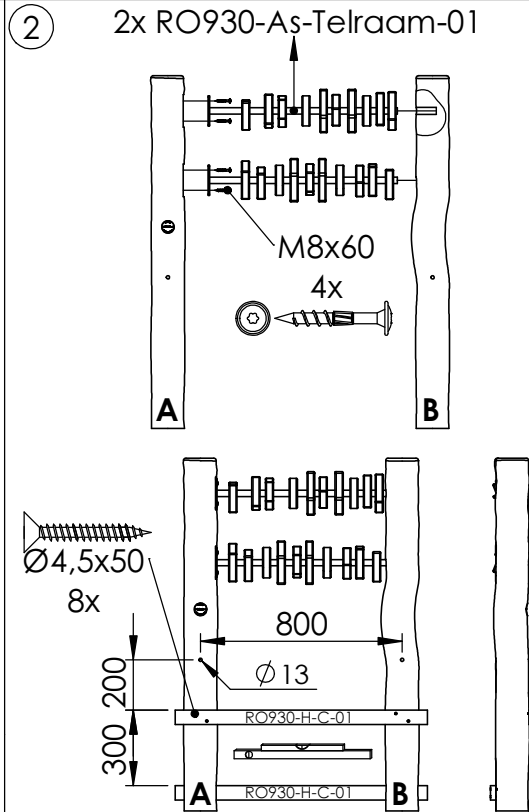
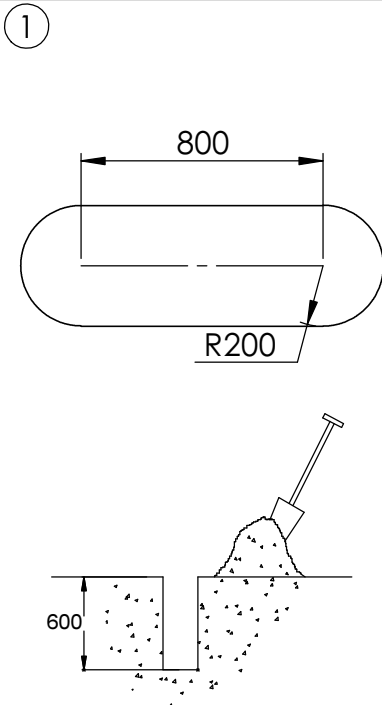

AFMETINGEN  
DIMENSIONS  
MASSE  
DIMENSIONES  
DIMENSIONI  
L: 1,2m  
Br: 0,2m  
H: 0,8m

Bij droog weer moeten alle bouten en schroeven opnieuw aangespannen worden.  
Par temps sec il faut resserrer régulièrement toute la visserie.  
By dry and warm weather check the tightness of all bolts and screws.  
Bei trockenem Wetter müssen alle Schrauben und Bolzen aufs neue angespannt werden.  
Para el tiempo seco, se necesita cerrar o ajustar los tornillos y tuercas.  
Con tempo asciutto, tutti i bulloni e le viti devono essere avvitati nuovamente.